



TAI-SAW TECHNOLOGY CO., LTD.

No. 3, Industrial 2nd Rd., Ping-Chen Industrial District,
Taoyuan, 324, Taiwan, R.O.C.

TEL: 886-3-4690038 FAX: 886-3-4697532

E-mail: tstsales@mail.taisaw.com Web: www.taisaw.com

Approval Sheet For Product Specification

Issued Date: 12/2/2005 (REV. NO: 1)

Product Name: SMD 5.0x3.2 10.368MHz Crystal Unit

TST Parts No.: TZ0792A

Customer Parts No. : _____

| |
|--------------------|
| Company: _____ |
| Division: _____ |
| Approved by: _____ |
| Date: _____ |

Checked by: _____ CC Hsu

Approval by: _____ TF Yang

Date: _____ 12/2/2005



TAI-SAW TECHNOLOGY CO., LTD.

No. 3, Industrial 2nd Rd., Ping-Chen Industrial District,
Taoyuan, 324, Taiwan, R.O.C.

TEL: 886-3-4690038 FAX: 886-3-4697532

E-mail: tstsales@mail.taisaw.com Web: www.taisaw.com

SMD 5.0x3.2 10.368MHz Crystal Unit

MODEL NO.: TZ0792A

REV. NO.: 1

Features:

- Surface Mount Seam Weld Package
- Excellent Reliability Performance
- Good Frequency Perturbation and Stability over temperature

RoHS Compliant
Lead free
Lead-free soldering

Description and Applications:

Surface mount 5.0mmx3.2mm crystal unit for use in wireless telecommunications devices, especially for a need of ultra miniature package for mobility.

Electrical Specifications:

| TZ0792A | Specification |
|--|--|
| Nominal Frequency | 10.3680 MHz |
| Mode of Oscillation | Fundamental |
| Storage Temperature Range | -40°C to +85°C |
| Operating Temperature Range | -10°C to +60°C |
| Frequency Stability over Operating Temperature Range | +/- 10 ppm (referred to the value at 25°C) |
| Frequency Make Tolerance (FL) | +/- 10 ppm @ 25°C +/- 3°C |
| Equivalent Series Resistance (ESR) | 100 Ω max |
| Nominal Drive Level | 10 uW |
| Shunt Capacitance (Co) | 5 pF max |
| Load Capacitance (CL) | 16 pF |
| Insulation Resistance | 500 MΩ min./DC 100V |
| Marking | Laser marking |

Mechanical Dimensions (mm):

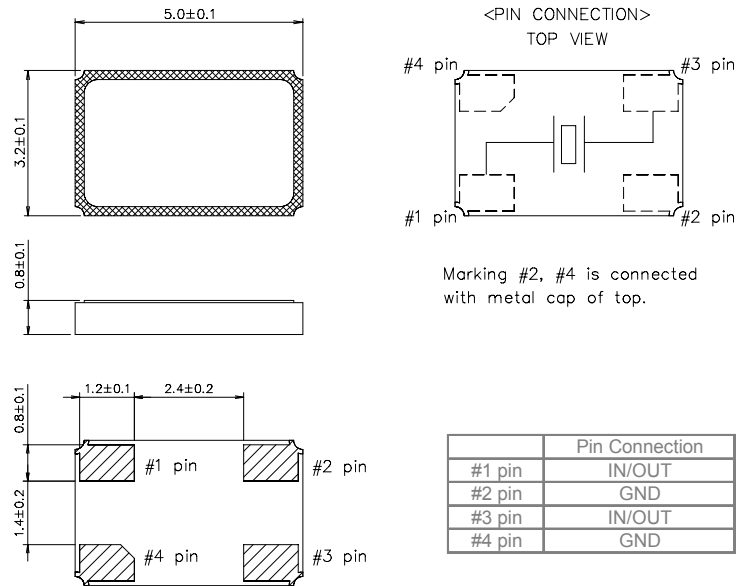

Recommended Land Pattern: (unit: mm)

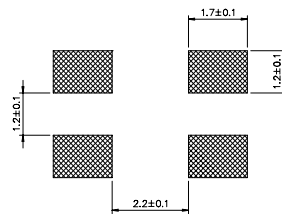

Marking:

Line 1: Frequency (10.368)

Line 2: TST Logo + Crystal Product Code + Date Code

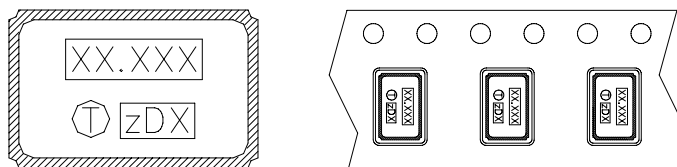

Product Code Table

| Year | 2001 | 2002 | 2003 | 2004 |
|--------------|------|------|----------|----------|
| | 2005 | 2006 | 2007 | 2008 |
| Product Code | Z | z | <u>Z</u> | <u>z</u> |

Date Code Table

| | | | | | | | | | | | | |
|------|------|------|------|------|------|------|------|------|------|------|------|------|
| WK01 | WK02 | WK03 | WK04 | WK05 | WK06 | WK07 | WK08 | WK09 | WK10 | WK11 | WK12 | WK13 |
| A | B | C | D | E | F | G | H | I | J | K | L | M |
| WK14 | WK15 | WK16 | WK17 | WK18 | WK19 | WK20 | WK21 | WK22 | WK23 | WK24 | WK25 | WK26 |
| N | O | P | Q | R | S | T | U | V | W | X | Y | Z |
| WK27 | WK28 | WK29 | WK30 | WK31 | WK32 | WK33 | WK34 | WK35 | WK36 | WK37 | WK38 | WK39 |
| a | b | c | d | e | f | g | h | i | j | k | l | m |
| WK40 | WK41 | WK42 | WK43 | WK44 | WK45 | WK46 | WK47 | WK48 | WK49 | WK50 | WK51 | WK52 |
| n | o | p | q | r | s | t | u | v | w | x | y | z |

Reel Dimensions (mm):

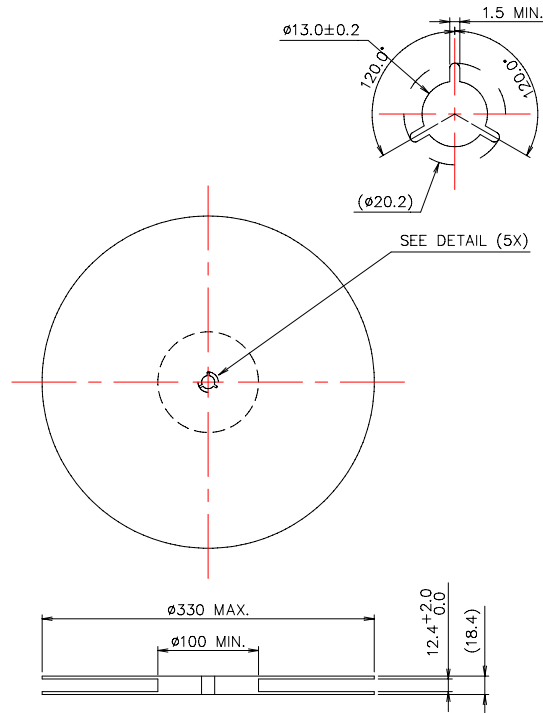

Tape Dimensions (mm):

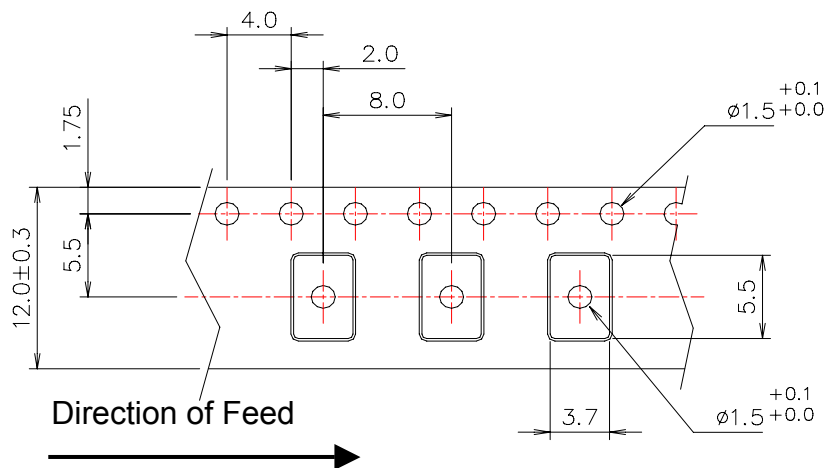

[NOTE]:

1. Unless otherwise specified tolerance on dimension ± 0.1 mm.
2. Material: conductive polystyrene with color black.
3. 10 pitch cumulative tolerance ± 0.2 mm.

Reflow Profile:

